

Selection manual of industrial control relay

RKM
Miniature General Purpose Relay

- 2 poles 5A, 4 poles 3A
- With LED integrated in relay
- With inspection window
- Shenler industrial relays are widely used in the output signal and safety drive of PLC, CNC system, robot, intelligent manufacturing and other control systems. It is the best choice to realize remote control, production and processing, packaging, transportation, testing, storage and other equipment and automatic assembly lines.

Metal clip
The relay is firmly attached to the socket by retaining clip.

LED
Visible LED indicates the working status of the relay at any time, AC red, DC green.

Silver alloy pins
High-quality silver alloy pins, strong contact, instantaneous conductivity and stable performance.

Silver alloy contacts
It can carry more current, with stronger conductivity and more sensitive response, and greatly extend electrical life, and works more stable.

Top copper coil material
Standard turns and electromagnetic coils make the pick-up more reliable and enduring, which can reach more than 20 million cycles.



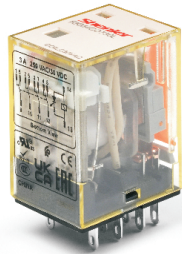

Relay

+



Socket

=



Relay module

RKM □ □ □ □

Other options

- L: LED
- LD: LED + diode (13-,14+)
- LD1: LED+diode(13+, 14-)

Coil voltage code

Code	006	012	024	048	110	220	
Voltage (V DC)	6	12	24	48	110	220	
Code	506	524	536	548	615	730	880
Voltage (V AC)	6	24	36	48	115	230	380

Terminal arrangement

O: plug in

Contact form

- 2C: 2CO
- 3C: 3CO
- 4C: 4CO

Series name

Characteristics

Configuration	2C/3C	4C	
Load	Resistance	5A/250VAC, 30VDC	3A/250VAC, 30VDC
	Motor load	1/3HP, 240VAC	1/6HP, 240VAC
Max. switching capacity (resistive)	1250VA, 150W	750VA, 90W	
Contact	Min. switching capacity	170mW(17V/10mA)	
	Initial contact resistance	≤50mΩ	
	Material	Ag alloy	
	Electrical durability	≥10 x 10 ⁴ Cycles (1800 Ops/h)	
	Mechanical durability	≥2000 x 10 ⁴ Cycles (18000 Ops/h)	
	Pick-up voltage (23°C) (Rated voltage)	DC:≤75%, AC:≤80% 50/60Hz	
Drop-out voltage (23°C) (Rated voltage)	DC:≥10%, AC:≥30% 50/60Hz		
Maximum voltage (23°C) (Rated voltage)	110%		
Insulation resistance	≥500MΩ (500VDC)		
Coil operating power	DC(W)	approx. 0.9	
	AC(VA)	approx. 1.2(60Hz)	
Operate time&Release time (at nominal voltage)	≤20ms		
Initial breakdown voltage	Between open contacts	1000VAC/1min (leakage current 1mA)	
	Between poles	2000VAC/1min (leakage current 1mA)	
	Between contacts and coil	2000VAC/1min (leakage current 1mA)	
Insulation characteristics	Rated voltage	250VAC	
	Pollution level	3	2
IEC 60664 UL840	Overvoltage level	III	II
Impulse withstand voltage (waveform: 1.2/50us)	4000V(Altitude 2000m)		
Protection level	IP20		
Storage temperature/ humidity	-55~+85°C/ ≤85%RH (18 months)		
Working temperature/ humidity	-55~+70°C/ 5%~85%RH (No condensation) ★		
Air pressure	86~106KPa		
Shock resistance	10G (half-sine shock pulse: 11ms)		
Vibration resistance	10~55Hz double-amplitude:1.0mm		
Mounting	plug in		
Unit weight	approx. 35g		

★ If the storage exceeds 18 months (calculated from the factory date), it is recommended to re-test the parameters before using.

Coil Specifications (23°C)

Nominal voltage V.DC	6	12	24	48	110	220	
Coil resistance Ω	40	180	640	2600	13000	42000	
Nominal voltage V.AC	6	24	36	48	115	230	380
Coil resistance Ω	11.5	180	370	640	4430	16500	42000

Coil resistance: under coil voltage 110V are measured with tolerance of $\pm 10\% \Omega$, above 110V with tolerance of $\pm 15\% \Omega$.

Contact Specification

RKM2CO Electrical durability contacts

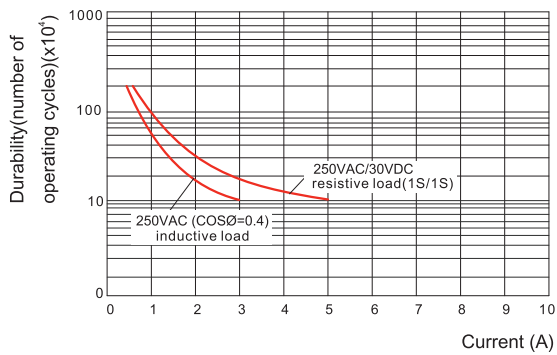

Maximum switching capacity

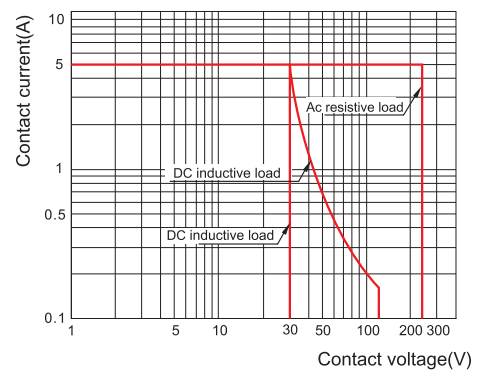

RKM4CO Electrical durability contacts

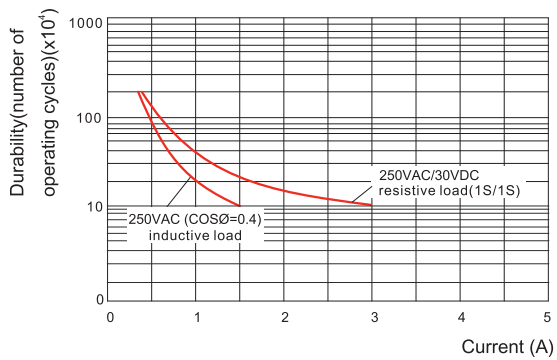

Maximum switching capacity

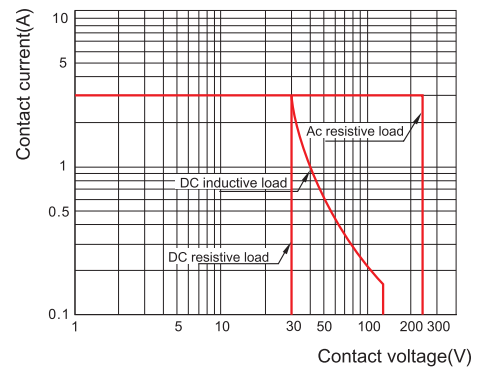

Dimensions (mm)

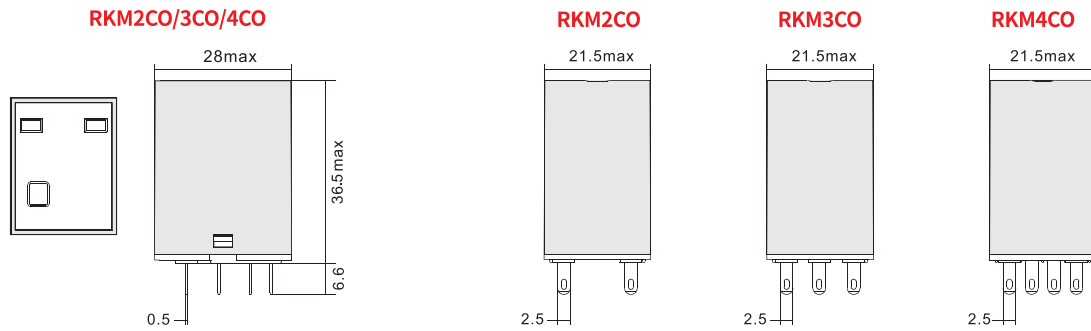

Wiring Diagrams

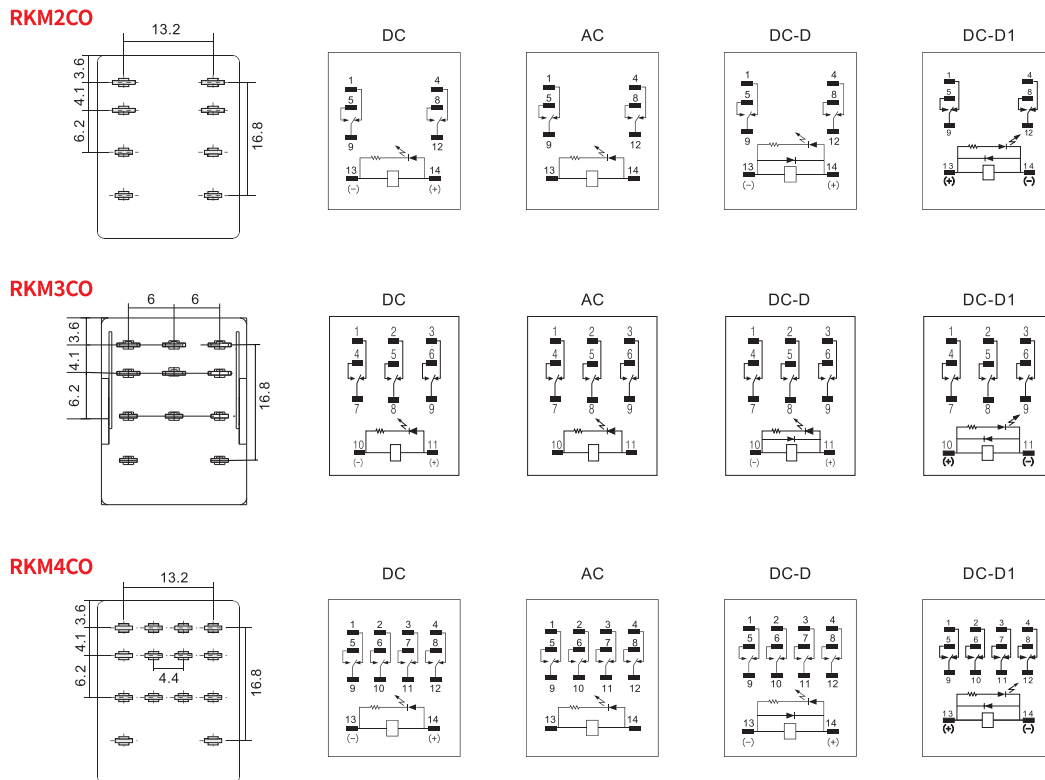

Characteristics



SYF08A-E

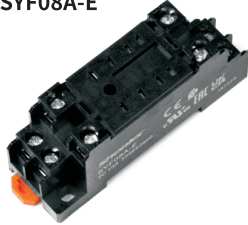

SYF14A-E



Type			SYF08A-E	SYF11A-E	SYF14A-E
Nominal load	Current	A	10	7	7
	Voltage	V	300		
Dielectric strength	Between coil and contact	V/min	3000		
	Between contacts	V/min	2000		
Max. tightening torque	Nm	1.0			
Wire size	AWG/mm ²	20-14/0.5-2.5			
Ambient temperature	°C	-40~+85			
Unit weight	g	37	56	57	

Accessories

Socket	Bus jumper	Metal clip
SYF08A-E	 SY08C SY10C	 SY36S
SYF11A-E		
SYF14A-E		

Dimensions (mm)

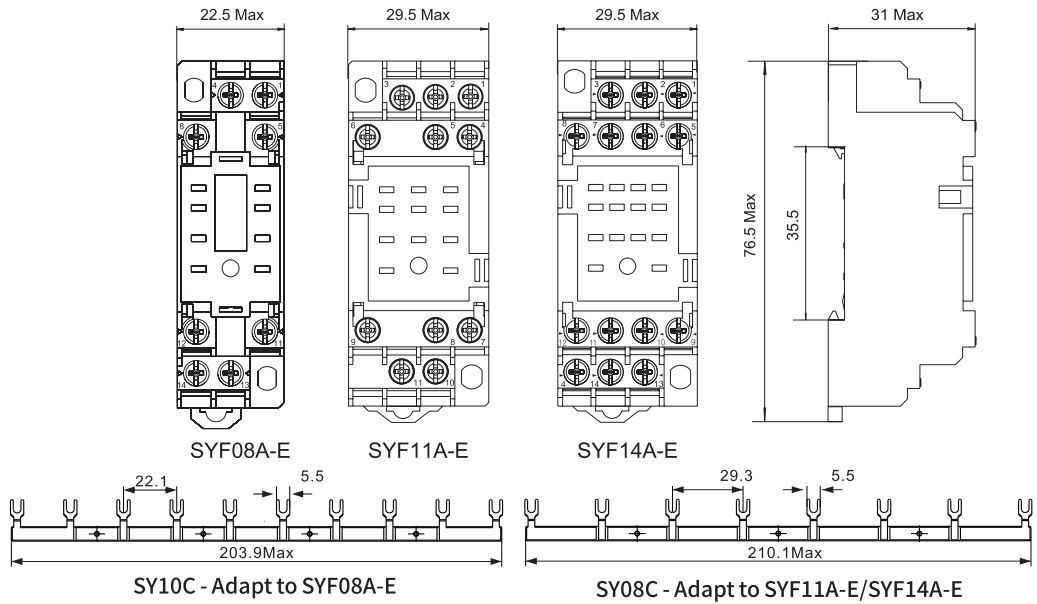

Connection Diagrams

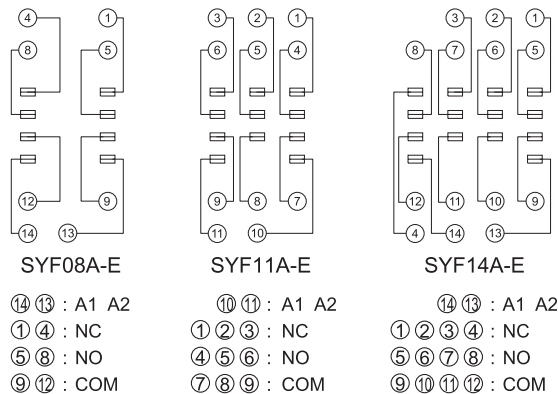

Characteristics



SYF08A



SYF14A

Type			SYF08A	SYF11A	SYF14A
Nominal load	Current	A	10	7	7
	Voltage	V	300		
Dielectric strength	Between coil and contact	V/min	3000		
	Between contacts	V/min	2000		
Max. tightening torque	Nm	1.0			
Wire size	AWG/mm ²	20-14/0.5-2.5			
Ambient temperature	°C	-40~+85			
Unit weight	g	34	47	56	

Accessories

Socket	Bus jumper	Metal clip
SYF08A	 SY08C SY10C	 SY36S
SYF11A		
SYF14A		

Dimensions (mm)

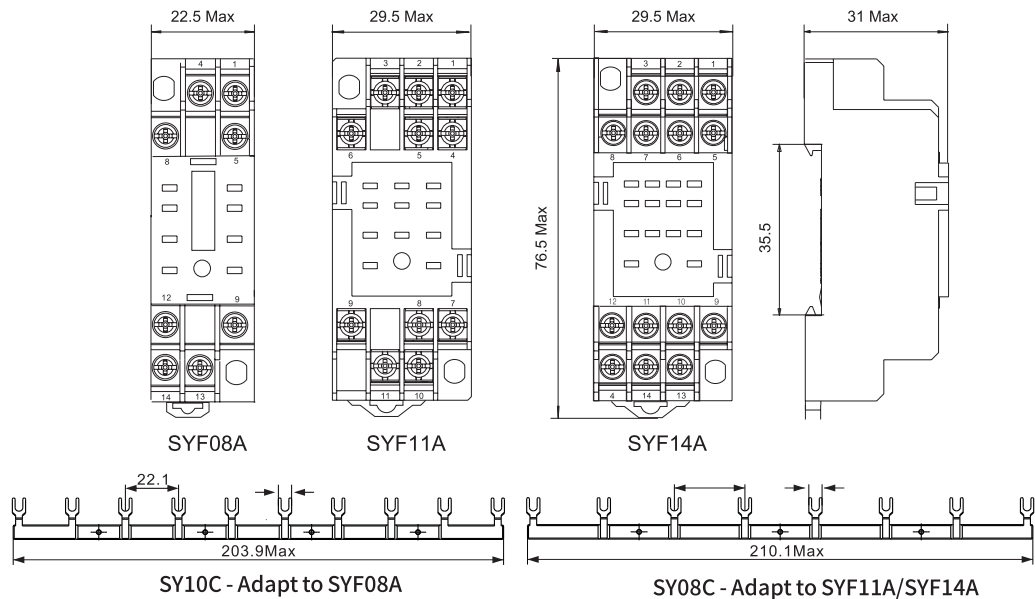

Connection Diagrams

