

Characteristics

SRC05-P





SRC08-P



Type		SRC05-P	SRC08-P
Nominal load	Current	A	12
	Voltage	V	300
Dielectric strength	Between coil and contact	V/min	4000
	Between contacts	V/min	2500
Max. tightening torque	Nm	-	
Wire size	AWG/mm ²	-	
Ambient temperature	°C	-40~+85	
Unit weight	g	10	10

Accessories

Socket	Metal clip
SRC05-P	 SR15M
SRC08-P	 SR1520M

Dimensions (mm)

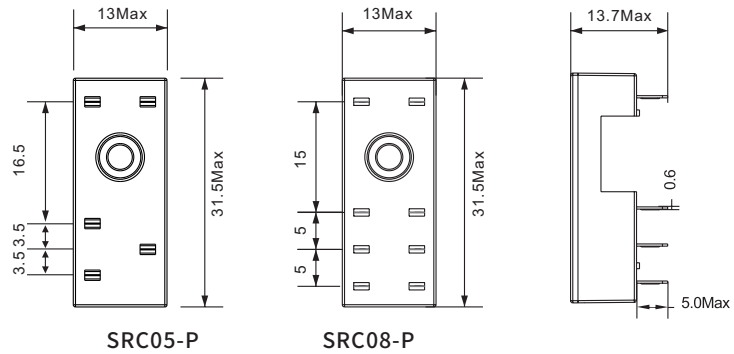

Connection Diagrams

